

SUMMARY

To upgrade a legacy networking system, a key challenge is to choose a flexible system that can accommodate future demand during a lifecycle of the system. Once selected, how to manage such new system for stable operation is another key point.

At Hanam City, the answer is to allow for the increase bandwidth and address space easily for future demand.

Responding to the City requirement, AMS Korea deployed the 10Gigabit/s and IPv6 capable system to cope with ongoing demand for several years to come.

CHALLENGES

As shown below, Hanam City legacy system can only support up to 1Gbps physical bandwidth and IPv4. IPv4 is being made obsolete by Korean Ministry of Communication to cope with shortage of IP address space.

Existing Network Management Systems can't analyze and cope with the abnormal traffic situation such as that caused by worm virus. Hence, Traffic Management needed to be implemented for stable networking operations.

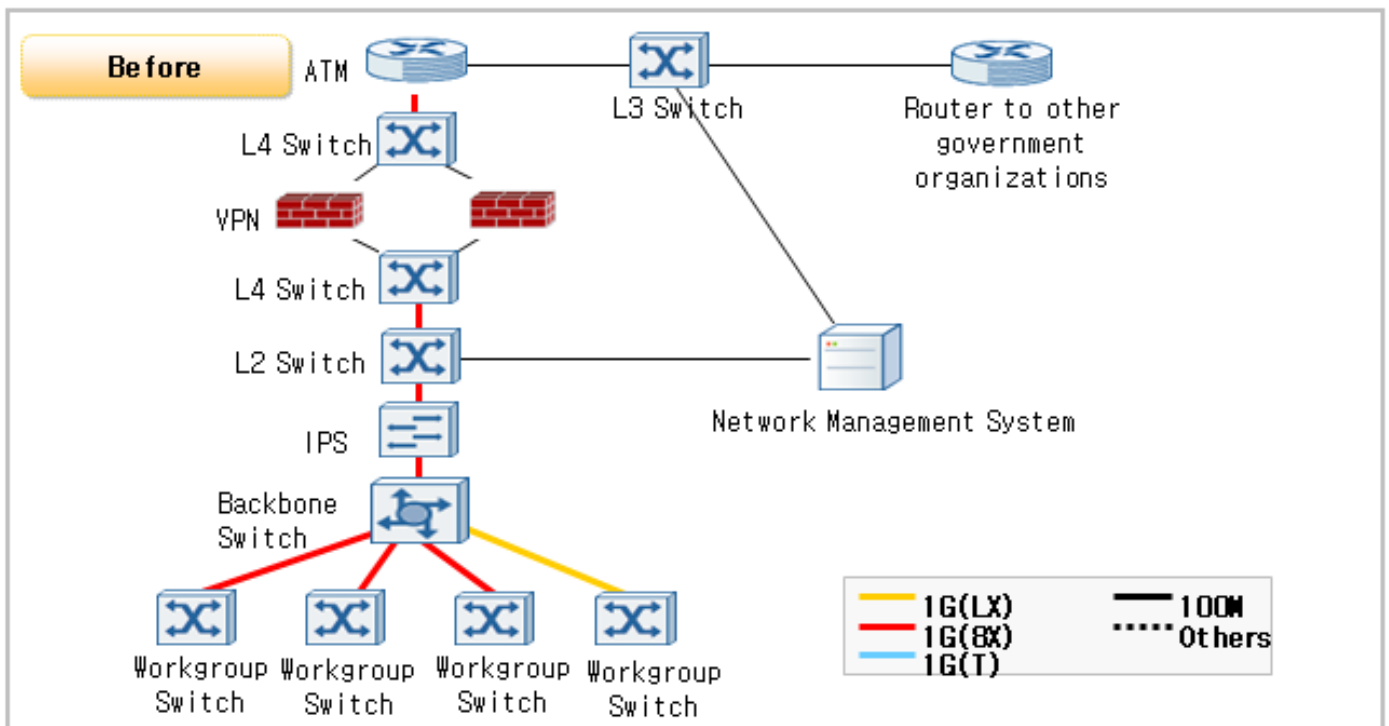

SOLUTIONS

As in the diagram, introduction of 10G-capable high-end backbone switch can provide adequate bandwidth for the future demand and dual connections between backbones and access switches improve redundancy for stable operations.

This IPv6-capable switch also can cope with future address shortage.

AMS Korea added Catchflow, a traffic management system based on "flow technologies" that can provide detailed traffic information and allow operators to monitor and precisely analyze network status.

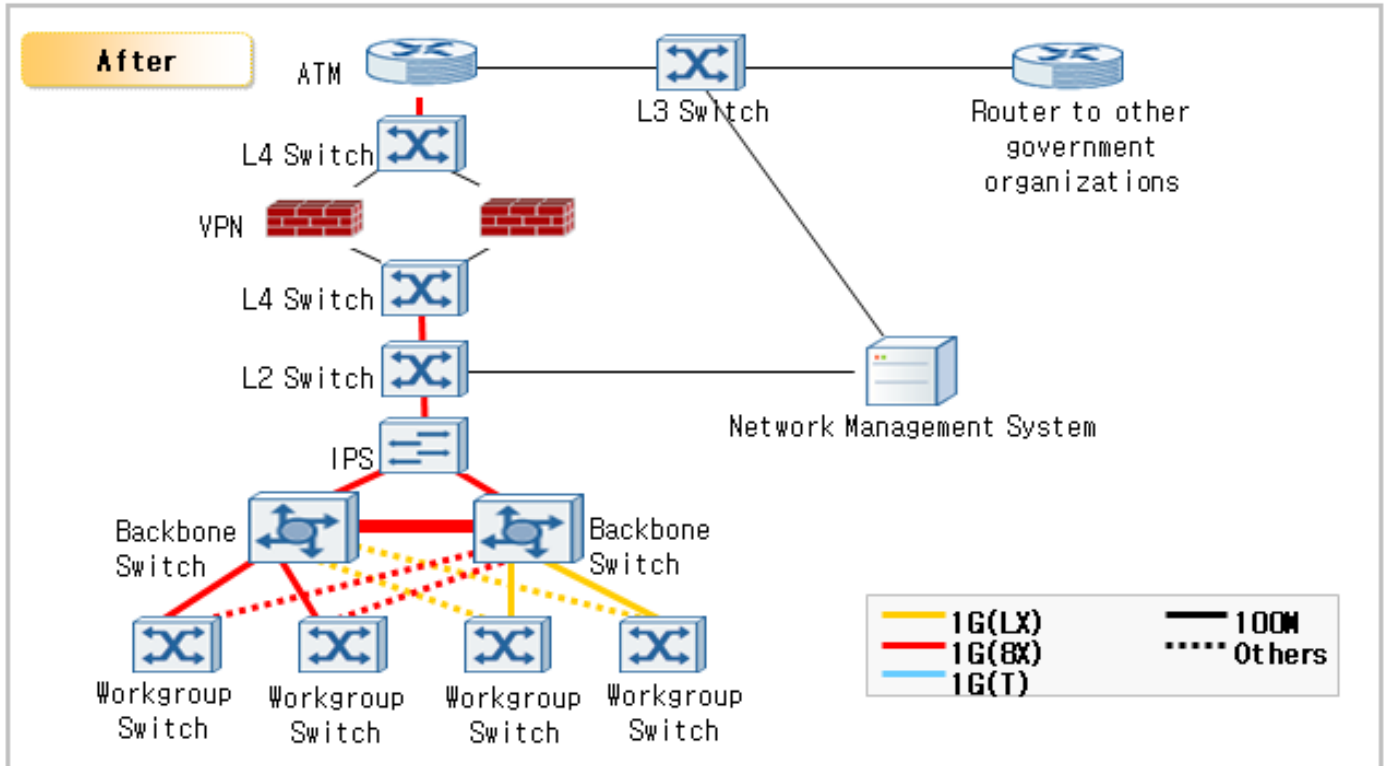

BENEFITS

Through the introduction of 10G and IPv6-capable backbone, Hanam City can be equipped with flexible and stable architecture for future expansion. And through the addition of traffic management onto NMS, the city can improve the stability of network operation.

CUSTOMER INFORMATION

Hanam city is geographically located to the middle east of the metropolitan area with a population of 130,000. 98% of the total land area is designated as a limited development district making it the most nature-friendly and green environment city among all the metropolitan cities.